

 **BULK
SYSTEM**
Loading Bellows Positioner
TR



THE FASTEST, EASIEST AND MOST EFFICIENT DUST-FREE LOADING POSITIONER FOR TANKERS, OPEN TRUCKS OR RAIL WAGONS

The TR Loading Bellow Positioner moves standard-duty loading bellows horizontally in the X-axis when loading trucks or rail wagons.

The back-and-front positioner enables the driver to stop the vehicle in the designated loading area without having to worry about being in the centre of the loading area.

The loading bellows is positioned above the vehicle hatch by being moved to the left or to the right.

Technical Features



- Inlet diameter 300 mm (22");
- Support frame manufactured from carbon steel painted in RAL 5010 (gentian blue);
- Hopper manufactured from carbon steel (standard version) or stainless steel on request;
- Hopper with 60° discharge angle moving on 4 wheels ;
- Outlet diameter 300 mm (22");
- Back-and-front positioner with horizontal travel of 1,000, 1,500 or 2,000 mm (3.2, 4.9 or 6.5 ft);
- Electric motor IEC Size 80; B14; 0.55 kW – 6 poles; 230/400 V 50 Hz – 260/460 V – 60 Hz;
- 2 electromechanical lever limit switches available for end of stroke detection; hopper equipped with 2 adjustable cams for position adjustment;
- Operating temperature: from - 20 °C up to 50 °C (from - 4°F up to 122°F).

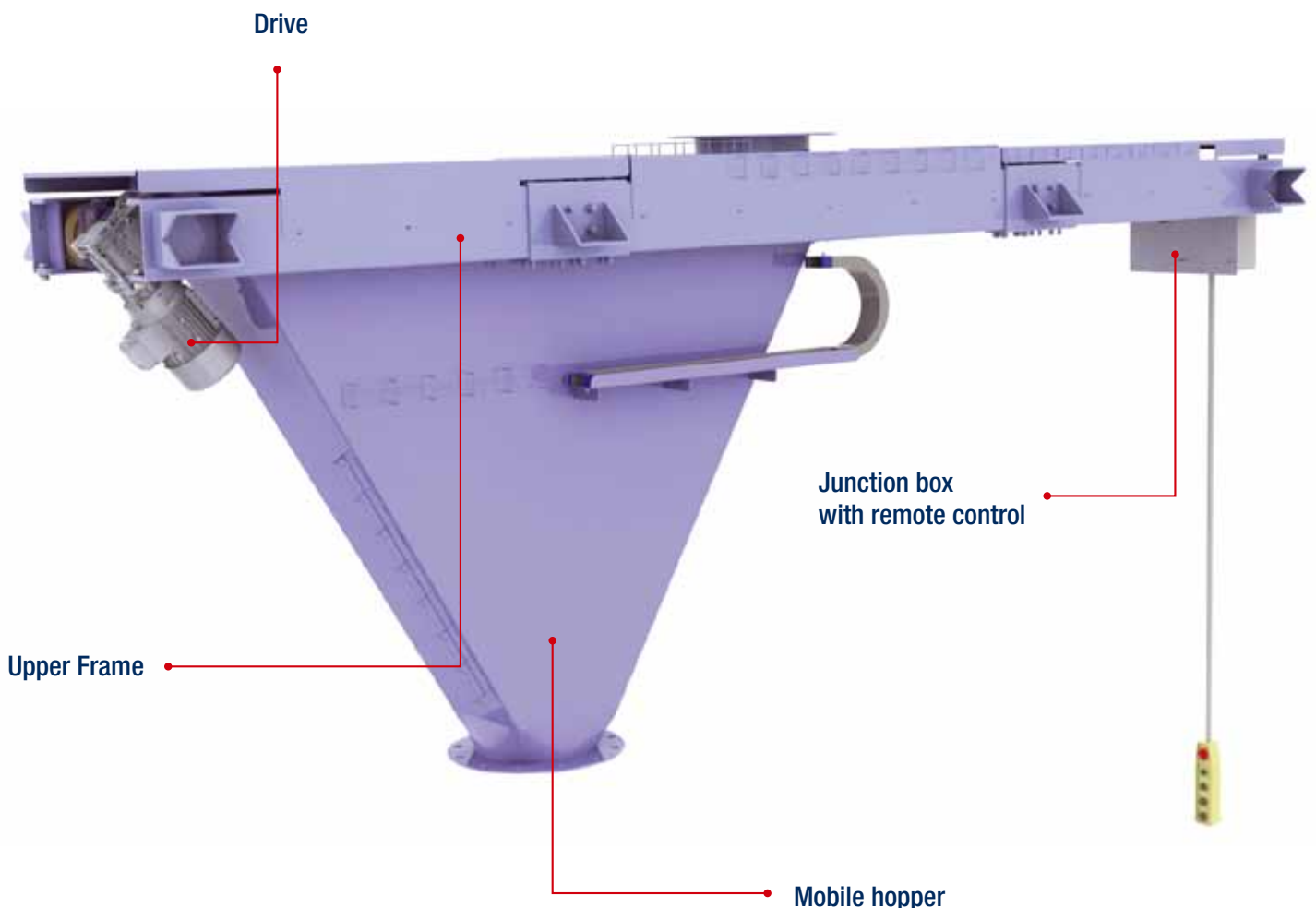

Benefits



- ✓ Acceleration in any loading operation;
- ✓ Eliminates vehicle re-spotting once in the loading area;
- ✓ Precisely positioned up to a maximum of 1,000 mm (3.2 ft) out of the centre of the loading bellows;
- ✓ Suitable for loading bellows with and without built-in filter;
- ✓ Factory pre-wired.

Accessories



Electric Control Panel and Remote Control for Automatic Loading Operation



Overall Dimensions

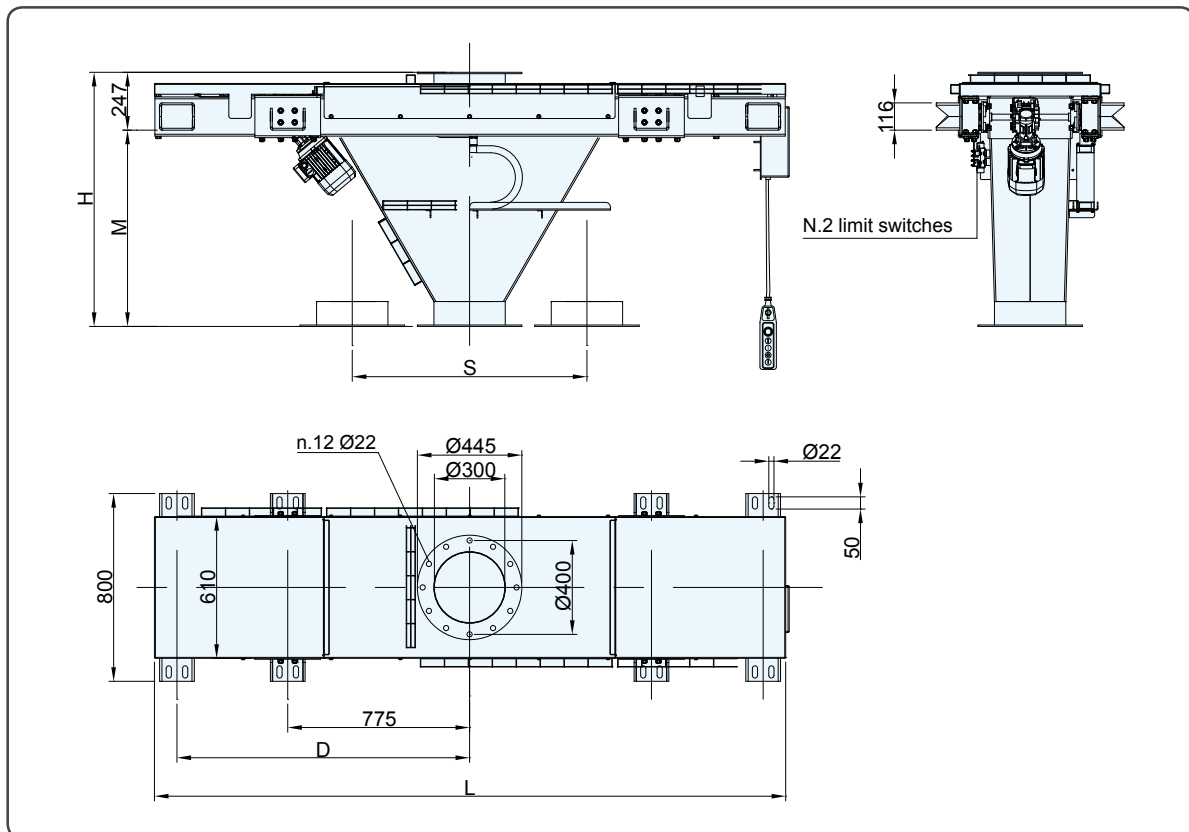

STROKE	1,000 mm	1,500 mm	2,000 mm
OVERALL WEIGHT	300 kg	400 kg	500 kg
A		247	
L	2,700	3,700	4,700
D	1,247	1,751	2,251
H	1,100	1,520	1,950
M	853	1,273	1,703
S	1,000	1,500	2,000