

# Telescopic Loading Bellows for Large Capacities

ZQ



# DEVELOPED FOR HIGH CAPACITIES AND DUST-FREE LOADING OF SHIPS, BARGES OR STOCKPILES

ZQ Loading Bellows are suitable for continuous duty reaching a maximum capacity of 1,800 m<sup>3</sup>/h (1,060 cfm). At the lower end they are equipped with a skirt which prevents dust emission during discharging. Bellows retraction is controlled by an electric winch. The unit is equipped with a flanged spigot to be connected on site to a remote dust collector.

## Features

- Inlet Diameter: 800 mm (32 in)
- Maximum Capacity: 1,800 m<sup>3</sup>/h (1,060 cfm)
- Maximum Extension: up to 30 metres (98.4 ft)
- Hoisting Motor Power: 5.5 kW;
- Operating Temperature: from -20 °C up to 150°C (-4 °F up to 302 °F);
- 3 off external lifting cables not in contact with material flow extend and retract the loader obstruction-free and wear-free;
- 3 off TILT-type level indicators outside the material flow.

*Sensing probes that measure the product pile and automatically raise the bellows as the pile height increases. These level indicators sense either the presence or the absence of material featuring an activation angle of 25° degrees from vertical.*



## Overall Dimensions

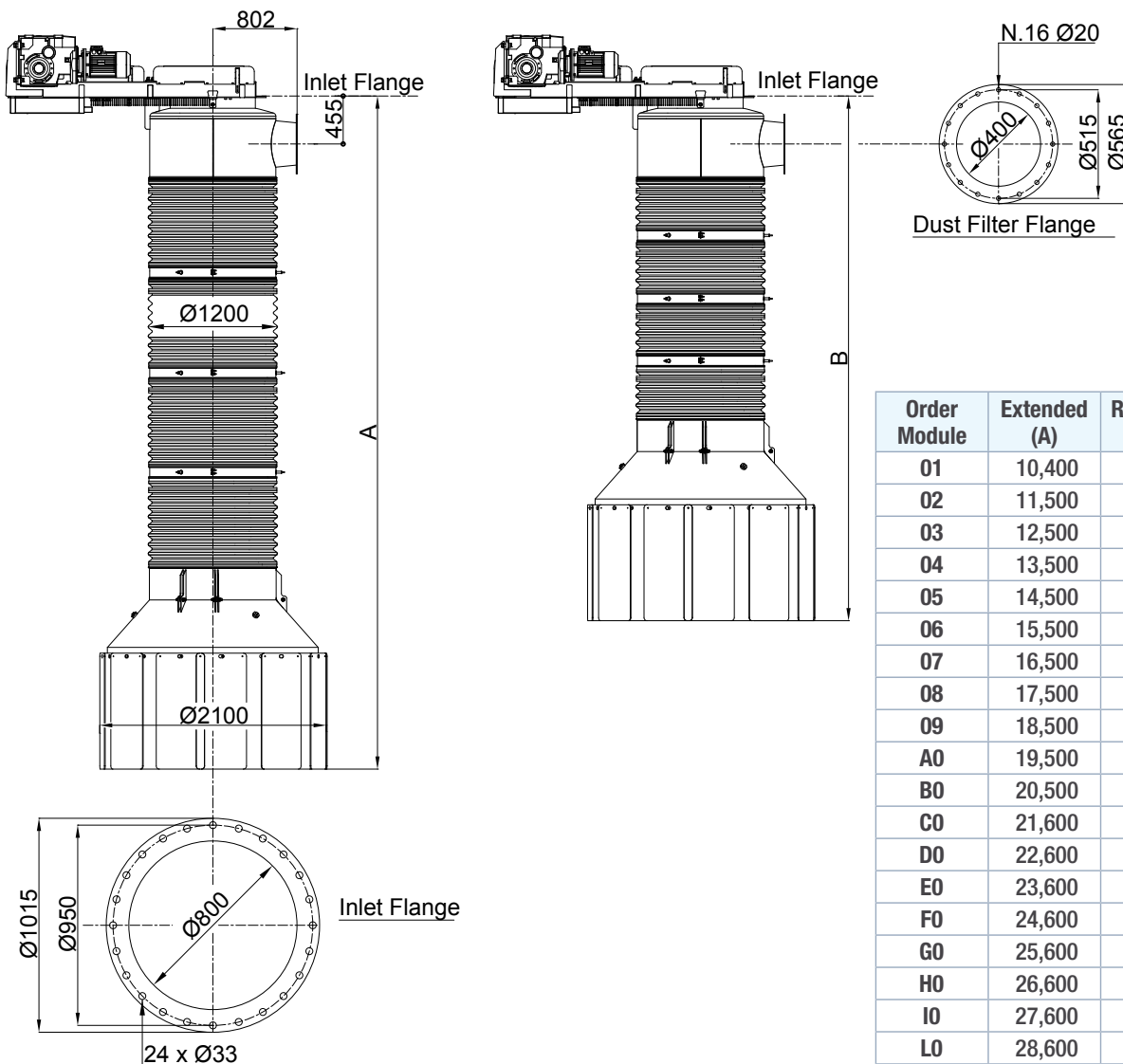

Order Module	Extended (A)	Retracted (B)	Weight (kg)
01	10,400	5,400	2,100
02	11,500	5,600	2,150
03	12,500	5,900	2,250
04	13,500	6,100	2,300
05	14,500	6,300	2,400
06	15,500	6,600	2,450
07	16,500	6,800	2,550
08	17,500	7,100	2,600
09	18,500	7,300	2,700
A0	19,500	7,500	2,750
B0	20,500	7,800	2,850
C0	21,600	8,000	2,900
D0	22,600	8,300	3,000
E0	23,600	8,500	3,100
F0	24,600	8,700	3,150
G0	25,600	9,000	3,250
H0	26,600	9,200	3,300
I0	27,600	9,500	3,400
L0	28,600	9,700	3,450
M0	29,600	9,900	3,550
N0	30,600	10,200	3,600

Dimensions in mm

## Benefits

- ✓ Excellent dust-free loading thanks to special bottom skirt design;
- ✓ Large capacities enable material loading in a short time;
- ✓ Various construction materials available to match all applications;
- ✓ Slack cable and upper/lower position limit switches, hoisting drive unit, 3 TILT level indicators are included in standard supply;
- ✓ Internal cones manufactured from either mild steel, wear-resistant or stainless steel;
- ✓ Bellows available in Hypalon®/Neoprene or food-grade polyester;
- ✓ Control panel with wireless remote control.

1 Motor Drive

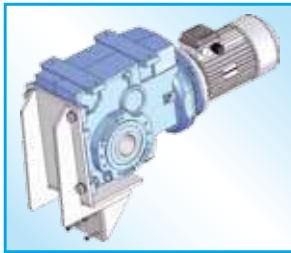

2 Chute Modules



3 Bottom Outlet With Skirt



4 TILT-type Level Indicators

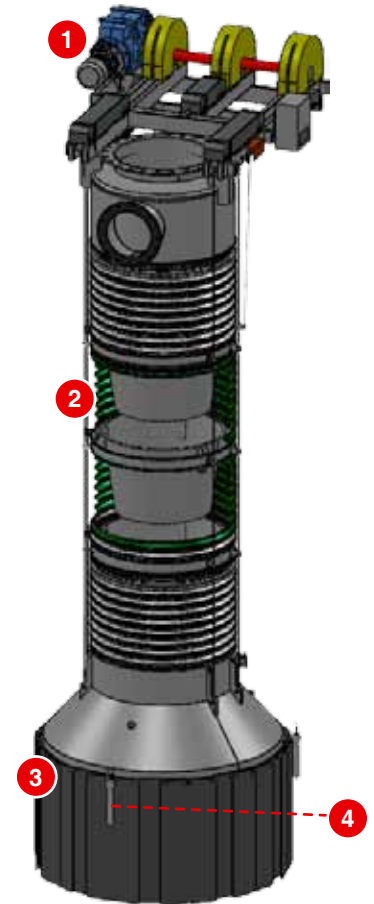

## Accessories

### Hypalon®-Neoprene Bellows



- Flexible Neoprene/Hypalon® chute results in high resistance to atmospheric agents and abrasion, making the loader durable.

### Food-Grade Polyester



- Flexible food-grade polyester chute results in high resistance to atmospheric agents;
- Suitable to be in contact with food products;
- Antistatic.

### Control Panel with Wireless Remote Control



- Consists of a receiver unit installed on the upper frame connected to the electrical panel and transmitter unit, pushbutton panel from which the operator can control the loading operations by pressing the buttons provided for the purpose;
- Comfortable use in any operating situation;
- Maximum operating distance: 100 metres.